



## FAA545 series

### DC-Operated, single-axis Linear Accelerometer

- Ranges  $\pm 2g$  to  $\pm 500g$
- Essentially zero temperature coefficient of damping ratio
- Integral temperature compensation
- DC input - DC output
- High reliability



The Altheris range of Solid State Accelerometers measure vector acceleration with high accuracy and incorporate a micromachined piezo-resistive strain gauge bridge silicon sensor incorporating an air damping feature. Unlike fluid damped devices the air damping employed is essentially independent of temperature. The transducer also incorporates positive mechanical stops conferring excellent shock resistance. The accelerometer is compensated for the effects of temperature on both sensitivity and zero.

Typical applications include data acquisition systems, crash recorders, fatigue life monitoring and prediction; monitoring and controlling deceleration in mass transit systems; road bed analysis and fault detection equipment for high speed railways; military and civil flight simulators; autopilots and low frequency vibration monitoring.

In addition to the instruments offered in this datasheet Altheris design and develop accelerometers for specific applications. These custom designed units can be manufactured and tested to conform to specific requirements and standards.

Designed for operation from an unregulated DC power source, the FAA545 is packaged in a robust aluminium alloy housing with solder pin connections. The accelerometer has a wide-range useable frequency response from DC to several kHz.

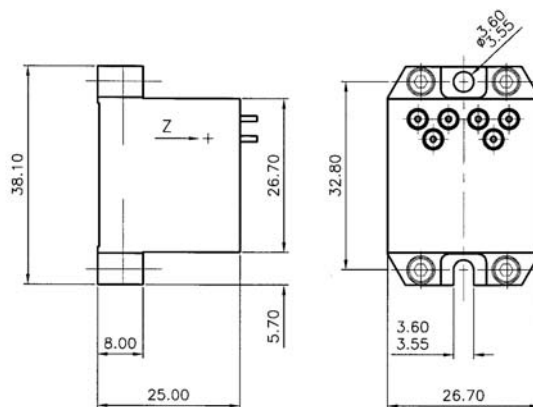

## ■ General specification

### Input

Ranges (±g) 2; 5; 10; 20; 50; 100; 200; 500  
 Input Voltage ..... 14.5 to 27Vdc  
 Input Current ..... 5mA dc max.

### Output at 25°C

Zero Offset ..... ≤ ± 2 mV  
 Nonlinearity ..... ≤ ±0.5% FRO  
 Hysteresis ..... ≤ 0.02% FRO  
 Resolution ..... ≤ 0.0005% FRO  
 Cross Axis Sensitivity ..... ≤ ±1% FRO  
 Noise Output ..... 1µV (p-p) max  
 Damping Ratio ..... 0.7 (±0.2) @ 25°C  
 Output Impedance. .... 2.5 to 6.5 kΩ

Range (g)	Sensitivity (Min/Max) (mV/g)	Resonant Frequency (Hz)	Frequency Response (Hz ± 5%)
± 2	6.0/9.0	700	0 to 250
± 5	2.4/3.6	800	0 to 300
± 10	1.2/1.8	1000	0 to 400
± 20	0.6/0.9	1500	0 to 600
± 50	0.24/0.36	2000	0 to 1000
± 100	0.12/0.18	3000	0 to 1500
± 200	0.15/0.30	4000	0 to 2000
± 500	0.06/0.15	5000	0 to 2400

### Environmental

Temp. Operating ..... -40°C to +105°C  
 Temp. Compensated ..... 0°C to +50°C  
 Temp. Storage ..... -55°C to +130°C  
 Thermal Sensitivity Shift ..... ≤ ±0.02% FRO/°C  
 Thermal Zero Shift ..... ≤ ±0.02% FRO/°C  
 Acceleration limit 400g for 2 to 10 g versions, 20 x range or 2000g, whichever is lower for other versions (any direction)  
 Humidity/Immersion ..... IP65  
 Insulation Resistance ..... ≥ 20 MΩ at 50V dc

### Physical

Sensitive Axis Alignment Vertical to mounting face  
 Weight ..... 40 grams max

### Electrical Connections

Solder Pin Connections ..... Pin A - + dc excitation  
 Pin B - 0V dc excitation  
 Pin C - Signal  
 Pin D + Signal  
 Pin E – not connected  
 Pin F – not connected

## ■ Ordering code

### DESIGNATION & ORDERING CODE

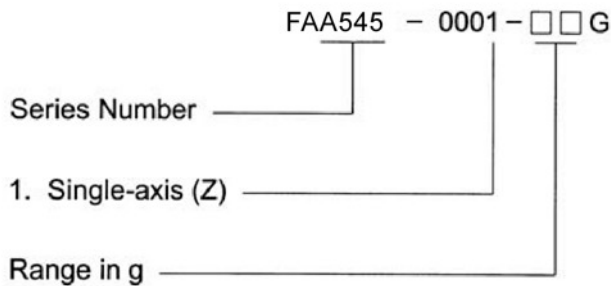

## ALTHERIS bv

Scheveningseweg 15  
 2517 KS DEN HAAG  
 The Netherlands

+31 (0)70 3924421

+31 (0)70 3644249

Offices in : Benelux | Germany | France | UK | Italy | USA

www.altheris.com

sales@altheris.nl

LEADERS IN SENSORS & HEAVY DUTY JOYSTICKS

**ALTHERIS**  
 SENSORS & CONTROLS