



FDMK77 digital Draw-wire sensor

- Robust plastic housing
- Customized versions for OEM
- Incremental/absolute encoder

The miniature draw-wire sensors of the FDMK series are specially designed for use in high-volume production. Due to the favorable price and the compact size of the sensor, new potential designs and cost optimization are the benefits to the user.



FDMK77

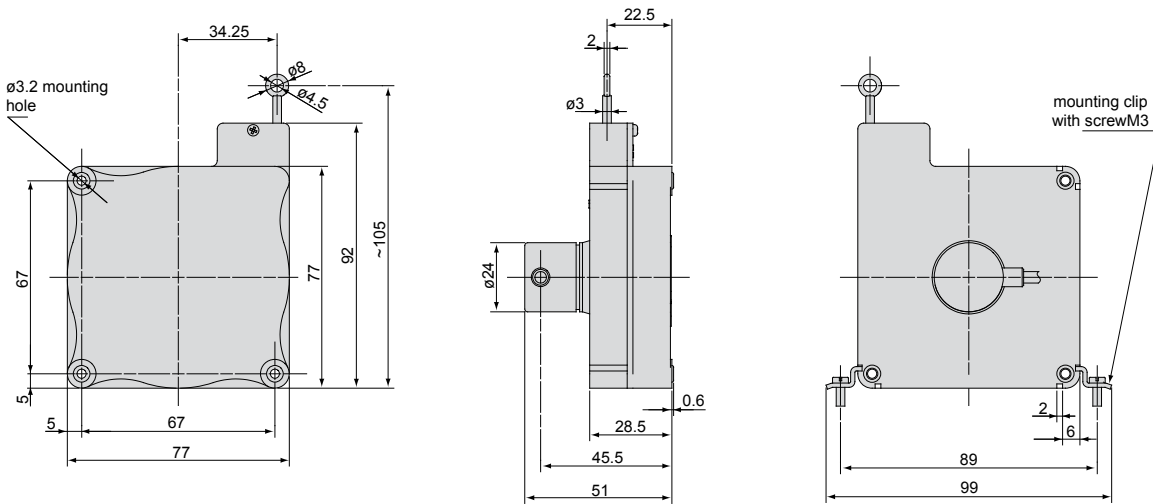

■ Technical data

Model	FDMK77-2100	
Output	E/E830	
Measuring range	2100mm	
Linearity	1.05mm	
	±0.05% FSO	
Resolution	0.43mm	
Sensor element	incremental encoder	
Temperature range	-20 to 80°C	
Material	housing	Plastic
	draw wire	coated polyamid stainless steel (ø 0.45mm)
Wire mounting	Eyelet	
Cable diameter	0.45mm	
Sensor mounting	mounting holes / mounting grooves	
Wire retraction force (min)	3.5N	
Wire extension force (max)	5N	
Wire acceleration	5g	
Protection class	IP 54	
Electrical connection	cable radial, 2m	
Weight	appr. 0.27kg	

FSO = Full Scale Output

■ Ordering code

FDMK77 - 2100 -	E
	Output option: encoder E (5 ... 24VDC) encoder E830 (8 ... 30VDC)
	Measuring range in mm
FDMK77	

LEADERS IN SENSORS & HEAVY DUTY JOYSTICKS

ALThERIS bv

Scheveningseweg 15
2517 KS DEN HAAG
The Netherlands

+31 (0)70 3924421

+31 (0)70 3644249

Offices in : Benelux | Germany | France | UK | Italy | USA

www.altheris.com

sales@altheris.nl

ALThERIS
SENSORS & CONTROLS