



## LBB series Ultra-precision Gage Heads

### Linear Ball bearing design, spring-extend and air-extend



The Linear Ball Bearing (LBB) series of dimensional gaging probes is engineered for highly precise and repeatable measurements in quality control and metrology applications. LBB within the gaging probe minimize radial play and friction for ultra-precise measurement. Bearing assemblies utilize two circumferential rows of miniature balls held in position by a retainer. The balls ride on a non-rotating plunger hardened to Rockwell 65, hard-chromed plated and precision ground for optimal repeatability and resistance to brinelling. The contact end of the plunger has a removable tungsten carbide ball tip, with an AGD standard 4-48 U NF-2A threading.

Plunger and bearings are enclosed in a cylindrical housing, hand-honed and fit to the ball bearing assembly. Precision fitting provides for exceptional gage head repeatability. With the bearings and housing essentially matched in hardness, the plungers can better tolerate side loads for a longer unit life.

#### LVDT Configuration

A Linear Variable Differential Transformer (LVDT) is contained in the opposite end of the tubular housing. With no physical contact between its core and coils, the LVDT produces a highly repeatable, low noise output voltage linearly proportional to probe displacement. Output can be sensed, amplified and displayed with any Altheris LVDT compatible signal conditioner, digital readout or LVDT computer based system.

LBB gage heads feature a unique two-piece construction. Units, therefore, are repairable should either probe structure or cables become damaged. A bend relief spring prevents cable damage at lead exit.

Positive mechanical stops prevent damage to the LVDT from severe impacts the end of the contact tip in cases of overstroke.

#### Features

- AC-operated
- Linear Ball Bearing Assemblies
- Removable Tungsten Carbide Contact Tip for Long-term Reliability and Interchangeability
- Double-shielded LVDT for Greater Protection from Effects of Magnetic Materials
- Polyurethane-jacketed Cable Enhances Flexibility and Improves Chemical Resistance
- Standard Viton Boot for Greater Resistance to Chemicals and High Temperatures

#### Applications

- Point-of-Manufacture status of production process standards
- On-line Inspection of Automobile Bodies
- Process Feedback for Numerically-Controlled Machine Tools
- Automated Data Collection For Factory SPC
- Robotics

## ■ Gage ranges

±0.020"	Spring-extend
±0.040"	Spring-extend
±0.100"	Air or Spring-extend
±0.200"	Spring-extend

## ■ Gaging methods

### Spring -Extend Gage Heads

Standard spring-extend LBB gage heads possess user-adjustable pretravel/overtravel settings. Units are available in both 3.15" (8 mm) and 0.375" (9.5 mm) diameters, with the latter available in both threaded and non-threaded housings. A 0.375" (9.5 mm) diameter, plain or threaded sleeve, can be provided for OEMS who want to stock one model with two diameters.

### Air-Extend, Spring-Retract Gage Heads

Air-extend, spring-retract units are manufactured in a ± 0.100" (± 2.5 mm) gaging range. These units require dry, oil-free air at 5 to 15 psi (0.34 to 1 bar). by varying air pressure, users can control gaging force to ensure the probe does not damage finely finished surfaces or distort delicate parts. Air extend models are available in 0.375" diameters with either threaded or non-threaded housings.

## ■ Common specifications

Input Frequency	2.5 to 10 kHz
Linearity	< ± 0.20% of full range output
Repeatability	0.000004" (0.10Fm)
Operating Temp. Range	-45°F to 160°F (-40°C to 70°C)
Temperature Coefficient of Sensitivity	± 0.005% of full range output/°F (± 0.01% of full range output/°C)
Housing Material	High carbon, chromium heat treated tool steel
Cable	6.5 feet (2 meters), 32 AWG stranded, PTFE insulated, shielded polyurethane jacket, 6 conductor
Cable Exit	Axial standard; adaptor provided with most units allow for radial exit

■ **±0.020 Range, Spring-extend Design**

**Features**

- Ultra-Precision Performance
- AC-Operated
- User-Adjustable Pretravel and Overtravel Settings
- 0.315" (8 mm) or 0.375" (9.5 mm) Body Diameter
- Plain or Threaded Housing
- Calibration Certificate Supplied with Every Gage Head
- Compatible with All Altheris Signal Conditioners
- 4 Connector Options

■ **Electrical specifications**

Excitation	3.5 V <sub>rm</sub> sat 5.0 kHz (nom)
Sensitivity	6.9 – 7.2 m V/V/.001"
Null Voltage	2.0 mV (max)
Phase Shift	6.5° ±3°
Primary Impedance	405 ohms
Secondary Impedance	1320 ohm s

■ **Wiring**

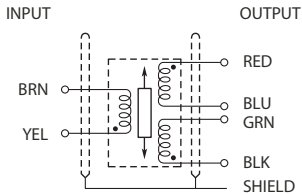

Note:  
 BLU and GRN tied for differential output with YEL and BLK common.  
 The output is in phase, with core displaced toward cable end. (Retract)

■ **Ordering information**

Specify the appropriate model number followed by the desired connector number. For example: LBB375PA-020-1.

Model Number	Body Diameter	Housing
LBB 315PA-020	0.315"	Unthreaded
LBB 375PA-020	0.375"	Unthreaded
LBB 375TA-020	0.375"	Threaded



■ **Mechanical specifications**

Pre travel	0.002" to 0.005"
Overtravel	0.005" (min)
Probe Force	2.47 oz (70g) nominal at null
Body Diameter	0.315" or 0.375"
Body Type	Plain or threaded
Cable Length	6.5' (2.0m )
Tip Thread	2.5 mm

■ **Dimensions (in mm)**

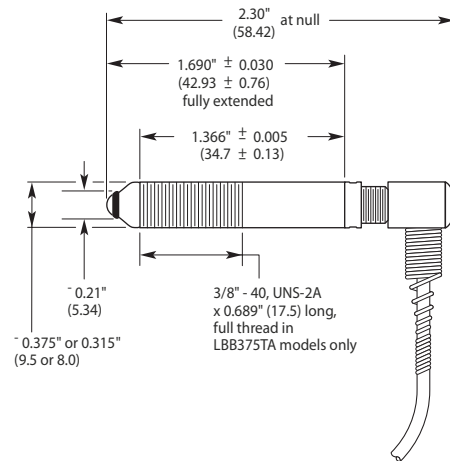

## ■ ±0.040 Range, Spring-extend Design

### Features

- Ultra-Precision Performance
- AC-Operated
- User-Adjustable Pretravel and Overtravel Settings
- 0.315" (8 mm) or 0.375" (9.5 mm) Body Diameter
- Plain or Threaded Housing
- Calibration Certificate Supplied with Every Gage Head
- Compatible with All Altheris Signal Conditioners
- 4 Connector Options
- Special Contact Tips



### ■ Electrical specifications

Excitation	3.5 Vrms at 5.0 kHz (nom)
Sensitivity	5.0 – 5.5 m V/V/.001"
Null Voltage	5.0 mV (max)
Phase Shift	3.0° ±3°
Primary Impedance	960 ohms
Secondary Impedance	2150 ohms

### ■ Mechanical specifications

Pre travel	0.002" to 0.005"
Overtravel	0.005" (min)
Probe Forc	2.47 oz (70g) nominal at null
Body Diameter	0.315" or 0.375"
Body Type	Plain or threaded
CableLength	6.5' (2.0m )
Tip Thread	4-48 AGD

### ■ Wiring

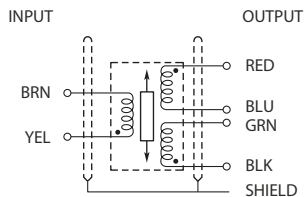

Note:  
BLU and GRN tied for differential output with YEL and BLK common. The output is in phase, with core displaced toward cable end. (Retract)

### ■ Dimensions (in mm)

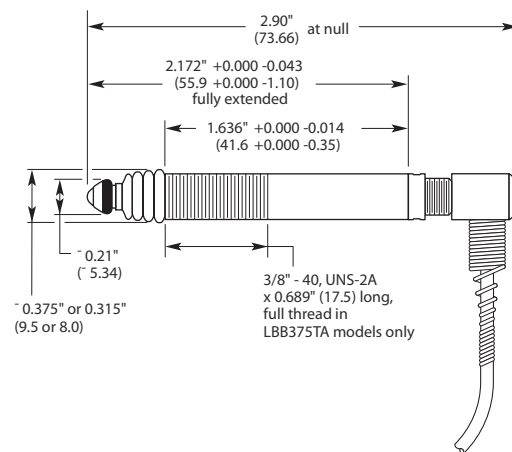

### ■ Ordering information

Specify the appropriate model number followed by the desired connector number. For example:

LBB 315PA-040-1. Special contact tips are also available and can be ordered separately.

Model Number	BodyDiameter	Housing
LBB 315PA-040	0.315"	Unthreaded
LBB 375PA-040	0.375"	Unthreaded
LBB 375TA-040	0.375"	Threaded

## ■ ±0.100 Range, Spring-extend Design

### Features

- Ultra-Precision Performance
- AC-Operated
- User-Adjustable Pretravel and Overtravel Settings
- 0.315" (8 mm) or 0.375" (9.5 mm) Body Diameter
- Plain or Threaded Housing
- Calibration Certificate Supplied with Every Gage Head
- Compatible with All Altheris Signal Conditioners
- 4 Connector Options
- Special Contact Tips



### ■ Electrical specifications

Excitation	3.5 Vrms at 5.0 kHz (nom)
Sensitivity	5.0 – 5.5 m V/V/.001"
Null Voltage	5.0 mV (max)
Phase Shift	3.0° ±3°
Primary Impedance	960 ohms
Secondary Impedance	2150 ohms

### ■ Mechanical specifications

Pre travel	0.002" to 0.005"
Overtravel	0.005" (min)
Probe Force	2.47 oz (70g) nominal at null
Body Diameter	0.315" or 0.375"
Body Type	Plain or threaded
Cable Length	6.5' (2.0m)
Tip Thread	4-48 AGD

### ■ Wiring

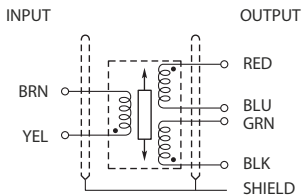

Note:  
BLU and GRN tied for differential output with YEL and BLK common. The output is in phase, with core displaced toward cable end. (Retract)

### ■ Dimensions (in mm)

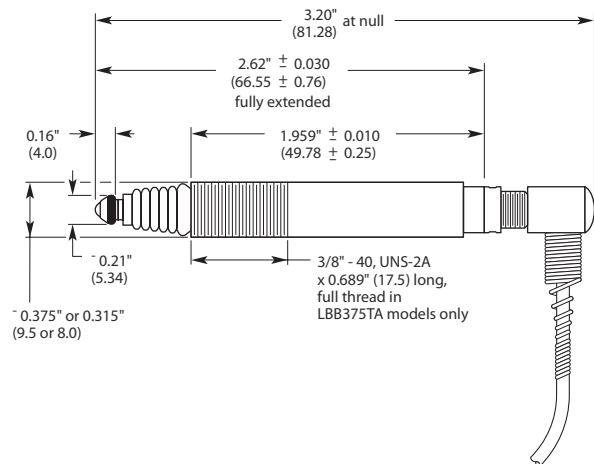

### ■ Ordering information

Specify the appropriate model number followed by the desired connector number.

For example:

LBB 375PA-100-1. Special contact tips are also available and can be ordered separately.

Model Number	Body Diameter	Housing
LBB 315PA-100	0.315"	Unthreaded
LBB 375PA-100	0.375"	Unthreaded
LBB 375TA-100	0.375"	Threaded

## ■ ±0.100 Range, Air-extend Design

### Features

- Ultra-Precision Performance
- AC-Operated
- 0.375" (9.5 mm) Plain or Threaded Housing
- Variable Probe Force
- Calibration Certificate Supplied with Every Gage Head
- Compatible with All Altheris Signal Conditioners
- 4 Connector Options
- Special Contact Tips



### ■ Electrical specifications

Excitation	3.5 Vrms at 5.0 kHz (nom)
Sensitivity	5.0 mV (max)
Phase Shift	±20°
Primary Impedance	260 ohm s
Secondary Impedance	215 ohm s

### ■ Wiring

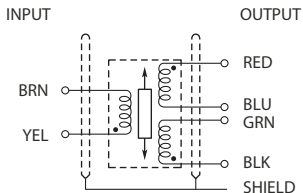

Note:  
BLU and GRN tied for differential output with YEL and BLK common. The output is in phase, with core displaced toward cable end. (Retract)

### ■ Ordering information

Specify the appropriate model number followed by the desired connector number.

For example:  
LBB 375PA-100A-1. Special contact tips are also available and can be ordered separately.

Model Number	Body Diameter	Housing
LBB 375PA-100A	0.375"	Unthreaded
LBB 375TA-100A	0.375"	Threaded

### ■ Mechanical specifications

Pre travel	0.005"
Overtravel	0.110" (min)
Probe Force	Variable
Body Diameter	0.375"
Body Type	Plain or threaded
Cable Length	6.5' (2.0m )
Tip Thread	4-48 AGD

### ■ Dimensions (in mm)

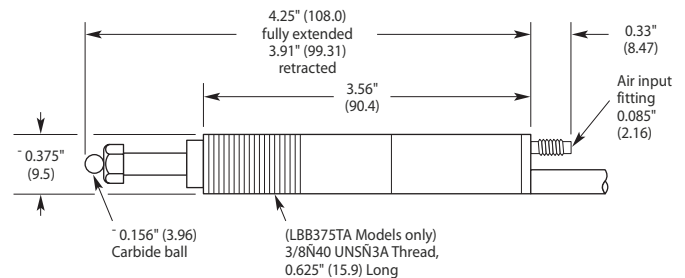

■ **±0.200 Range, Air-extend Design**

**Features**

- Ultra-Precision Performance
- AC-Operated
- 0.315" (8 mm) Body Diameter
- Plain Housing
- Calibration Certificate Supplied with Every Gage Head
- Compatible with All Schaevitz® Signal Conditioners
- 4 Connector Options



■ **Electrical specifications**

Excitation	5 V <sub>rms</sub> at 5.0 kHz (nom)
Sensitivity	4.3 mV/V/0.001"
Null Voltage	5.0 mV (max)
Primary Impedance	258 S
Secondary Impedance	711 S
Phase Shift	5.3° (at 5 kHz)

■ **Wiring**

Wiring Schematic

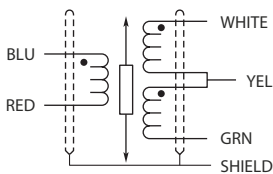

■ **Mechanical specifications**

Pre travel	0.005"
Overtravel	0.045" (min)
Probe Force	4.4 oz (125g) nominal at null
Body Diameter	0.315"
Body Type	Plain
Cable Length	6.5' (2.0m)
Tip Thread	2.5 mm

■ **Dimensions (in mm)**

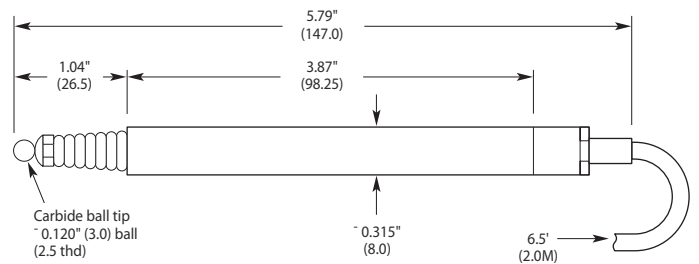

■ **Ordering information**

Specify the appropriate model number followed by the desired connector number.

For example:  
LBB315PA-200-1.

Model Number	Body Diameter	Housing
LBB 315PA-200	0.315"	Unthreaded

**ALTHERIS bv**

Scheveningseweg 15  
2517 KS DEN HAAG  
The Netherlands

+31 (0)70 3924421

+31 (0)70 3644249

Offices in : Benelux | Germany | France | UK | Italy | USA

www.altheris.com

sales@altheris.nl

LEADERS IN SENSORS & HEAVY DUTY JOYSTICKS

