

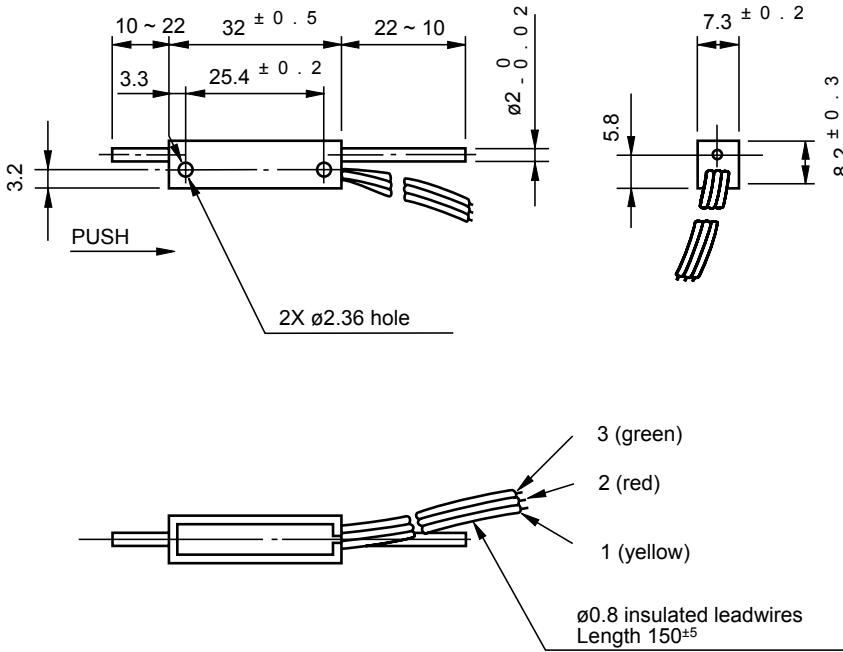

Model 8FLP10A

Low cost item (conductive plastic) With front and rear extended shaft

Standard dimensions



Model 8FLP10A

General Specifications

Standard Resistance

Values: 1k, 2k, 5k, 10k, 20k (Ω)

Max. Practical

Resistance Value: 50k Ω

Total Resistance

Tolerance: Standard Class $\pm 15\%$ (L)
 Precision Class $\pm 10\%$ (K)

Independent Linearity

Tolerance: Standard Class $\pm 2.0\%$
 Precision Class $\pm 1.0\%$

Resolution: Essentially Infinite

Output Smoothness: Within 0.1% against input voltage

Contact Resistance

Variation: Within 2% C.R.V.

Power Rating:

0.2W

Electrical Stroke:

11 ± 0.5 mm

Mechanical Stroke:

About 12mm

Insulation Resistance:

Over 1,000M Ω at 500 V.D.C.

Dielectric Strength:

1 minute at 500V.A.C.

Friction:

Within 0.3N (30gf)

Stopper Strength:

Approx. 10N (1kgf)

Resistance

Temperature

Coefficient:

± 400 p.p.m./ $^{\circ}$ C

Mass:

Approx. 5g

Special Specifications Available

Spring return device incorporated (friction is approx. 3N [300gf], special electrical stroke (8mm, 12mm), special machining on the shaft.

■ Special NOTE

When ordering special shaft length of our linear-motion potentiometers, especially models 30LP, 50LP, 8FLP and 15FLP series as standard version with front and rear shaft extension, please be sure to specify the shaft length exactly when the shaft is completely pressed into the housing.

Example: In case of model 8FLP10A standard version

As you see from the above right drawing, please specify the exact Length of L1 and L2 when the shaft is completely pressed into the housing.

In case of models with spring return device, the condition of spring returned is as right drawing and please specify the exact length of L1 and L2 when the shaft is completely pressed into the housing.

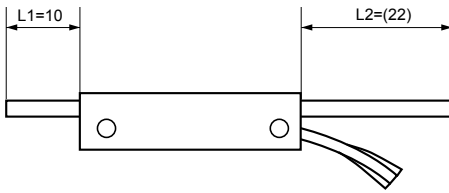

The condition of spring returned

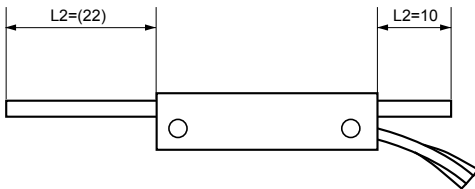

ALTHERIS bv

Scheveningseweg 15
2517 KS DEN HAAG
The Netherlands

+31 (0)70 3924421

+31 (0)70 3644249

Offices in : Benelux | Germany | France | UK | Italy | USA

www.altheris.com

sales@altheris.nl

LEADERS IN SENSORS & HEAVY DUTY JOYSTICKS

ALTHERIS
SENSORS & CONTROLS