

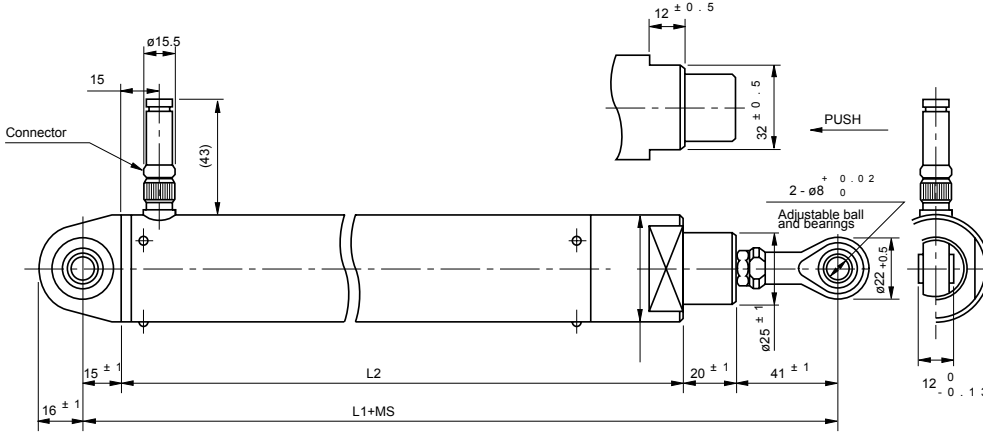

# Model OF40LP

Wirewound (With front extended shaft and with connector)

## Standard dimensions



Model No.	Mechanical Stroke	L1	L2
OF40LP100	Approx. 105	328	252
OF40LP200	Approx. 205	428	352
OF40LP300	Approx. 305	528	452

## Specifications of Connector

Water-proof type  
 Number of poles: 6 poles  
 Electrical wire diameter to be connected:  $\phi 6.3\text{mm}$  max

## Terminal Connection Diagram

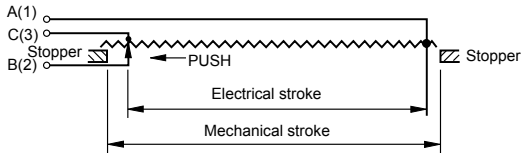

Model OF40LP300

## Standard Model Nos.

OF40LP100 stroke 100mm  
 OF40LP200 stroke 200mm  
 OF40LP300 stroke 300mm

## Standard Resistance Values | No. Of Wire Turns | Resistance Wire Used

Resist. Value ( $\Omega$ )	100	200	500	1k	2k	5k	10k	20k	50k	100k
OF40LP100	530	670	910	800	1,000	1,400	1,700	2,200	-	-
OF40LP200	830	1,050	1,400	1,800	1,600	2,200	2,850	3,450	4,900	-
OF40LP300	-	1,400	1,900	2,400	2,200	3,000	3,800	4,750	6,450	※8,000
Resist. Wire used	Cu-Ni System					Ni-Cr System				

Note: Mark ※ shows values at special higher practical resistance

## ■ General Specifications

Model No.	OF40LP100	OF40LP200	OF40LP300
Standard Resistance Range	100Ω ~ 20kΩ	100Ω ~ 50kΩ	200Ω ~ 50kΩ
Max. Practical Resistance Value	40kΩ	80kΩ	100kΩ
Total Resistance Tolerance	Standard Class	±5% (J)	
	Precision Class	±3% (H)	
Independent Linearity Tolerance	Standard Class	±0.5%	±0.3%
	Precision Class	±0.25%	±0.1%
Power Rating	1.0W	2.0W	3.0W
Noise	Within 100Ω E.N.R.		
Electrical Stroke	100±1mm	200±1mm	300±1mm
Mechanical Stroke	Approx. 105mm	Approx. 205mm	Approx. 305mm
Insulation Resistance	Over 100MΩ at 500V.D.C.		
Dielectric Strength	1 minute at 900V.A.C.		
Friction	Within 20N (2kgf)		
Stopper Strength	Approx. 90N (9kgf)		
Max. Working Voltage	300V		
Resistance Temperature Coefficient of Wire	±20 p.p.m./°C		
Mass	Approx. 1,000g	Approx. 1,200g	Approx. 1,500g

## ■ Special Specifications Available

Stroke 500mm (SOF40LP500), extra taps (available up to 1 tap), special machining on the shaft, non-oil-filled type, with conductive plastic resistive element.

### ALThERIS bv

Scheveningseweg 15  
2517 KS DEN HAAG  
The Netherlands

+31 (0)70 3924421

+31 (0)70 3644249

Offices in : Benelux | Germany | France | UK | Italy | USA

www.altheris.com

sales@altheris.nl

LEADERS IN SENSORS & HEAVY DUTY JOYSTICKS

**ALThERIS**  
SENSORS & CONTROLS