



AccuStar IP-66

4-20 mA Loop powered Clinometer

The AccuStar IP-66 is designed for rugged industrial and outdoor applications. The die-cast, powder coated aluminum housing is suitable for the most hostile environments. Multiple input / output configurations provide for ease of implementation into your application. When utilizing the 0.5 to 4.5 volt dc. output, the AccuStar IP-66 may be operated on a standard automotive 12-Volt dc. electrical supply. The water tight enclosure is suitable for use in tower crane and marine applications, under all weather conditions.



The 4 to 20 mA current output signal is ideal for machine control applications requiring long cable runs and provides for excellent noise immunity. An 18 to 30 Volt dc power supply is required for the 4 to 20 current signal output. EMI and RFI components have been incorporated in to the circuit design to provide noise immunity under the most severe conditions.

European CE certification, for EM I, RFI and ESD, is pending. The AccuStar IP-66 may be calibrated for full scale output for ranges from +/- 3.0° to +/- 45°.

Features

- Rugged, Die-Cast Aluminum Housing
- Dust & Water Tight to IP-66
- Ranges from +/- 3.0° to +/- 45°
- 4-Wire 0.5 to 4.5 Voltage Output
- 2-Wire Loop Powered Current Output
- 2-Meter Cable Connection

Applications

- Tower Crane Safety Systems
- RV Leveling Systems
- Machine Tool Angle Positioning
- Medical Trailer Leveling for Mobil CT & MRIs
- Barge Leveling and Load Distribution
- Water and Oil Well Drilling Rigs
- Mining Equipment

■ Specifications

| | |
|---------------------------------|---|
| Linear Ranges: | ± 3°, 5°, 10°, 15°, 20°, 30°, 45° |
| Voltage Supply (Un-regulated): | +12 to +30 VDC (24-volts required for 4 to 20 mA) |
| Output Signal: | 0.5 to 4.5 Vdc (or 4 to 20 mA) |
| Zero Point: | 2.5Vdc (or 12mA) |
| Max. Loop Resistance: | 500 Ohm at 24V DC |
| Linearity: | Null to +/- 10° +/- 0.1° +/-10° to +/- 45° +/- 1% of reading |
| Null Repeat ability: | 0.05° |
| Cross Axis error: | % up to 45° |
| Freq. Response (-3dB): | 0.5 Hz |
| Temperature Coefficient: | Null: 0.008°/°C |
| Scale Factor: | 0.1% /°C |
| Operating Temperature: Range: | -25 to +60° C |
| Dimension (inches) (L x W x H): | 3.86 x 2.48 x 1.38 |

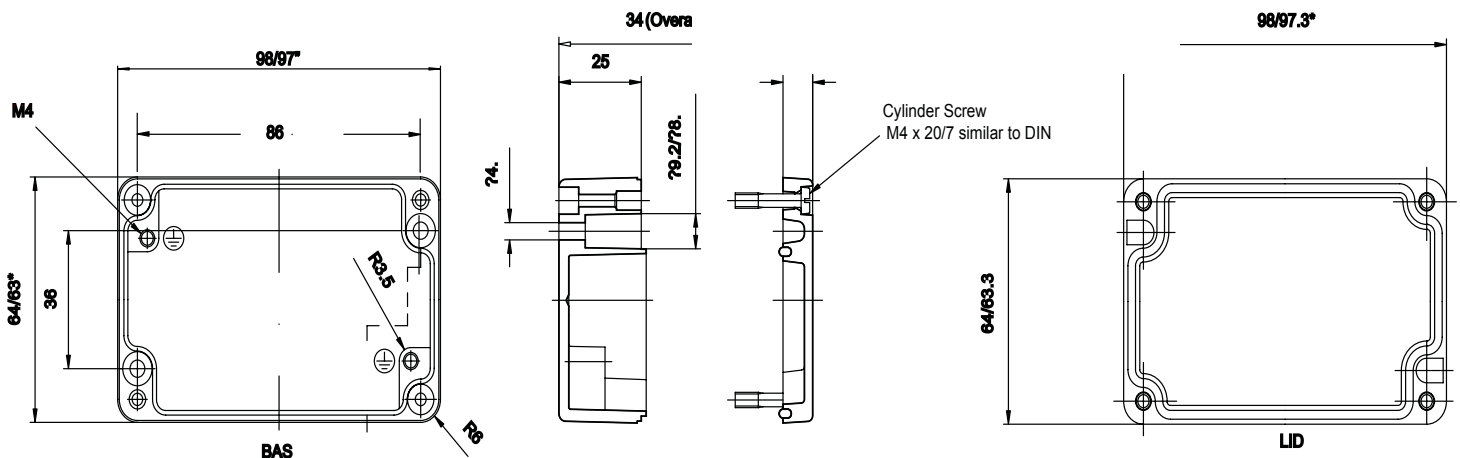

■ Connections

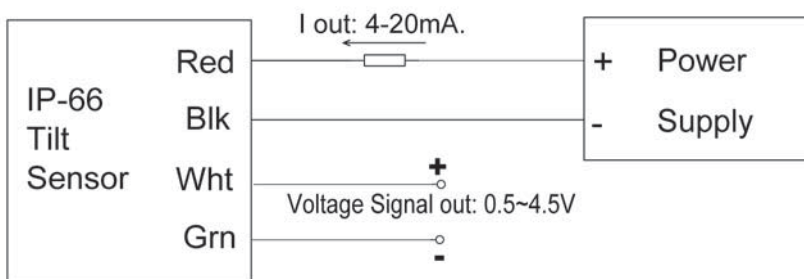

Note: Do NOT connect the Black and Green wires together.

ALTHERIS bv

Scheveningseweg 15
2517 KS DEN HAAG
The Netherlands

+31 (0)70 3924421

+31 (0)70 3644249

Offices in : Benelux | Germany | France | UK | Italy | USA

www.altheris.com

sales@altheris.nl

LEADERS IN SENSORS & HEAVY DUTY JOYSTICKS

ALTHERIS
SENSORS & CONTROLS