



AccuStar Electronic Clinometer

Single axis $\pm 60^\circ$ range

The AccuStar Electronic clinometer is an extremely accurate angle measurement device. This compact and rugged sensor is ideal where space is critical and environmental conditions are serious design concerns.

The heart of the system is a patented, capacitance-based sensor with no moving parts. When rotated about its sensitive axis, this unique sensor provides an exceedingly linear variation in capacitance, which is electronically converted into angular data. The sensor and low-power CMOS electronics are encased in a rugged plastic housing ready to install as a system component or as a stand-alone device.

Designed for easy integration, with a choice of analog, ratiometric, digital or serial models, the clinometer produces an output signal corresponding to direction and magnitude of angular displacement.



Features

- CE certified
- Just 2" in diameter
- Rugged plastic housing
- Extremely accurate
- Weighs only 2 oz.

Applications

- Wheel alignment
- Construction equipment
- Antenna positioning Robotics

Performance specifications

Total Range	$\pm 60^\circ$
Linear Range	$\pm 45^\circ$
Threshold	0.001°
Linearity	
Null to 10°	$\pm 0.1^\circ$
10 to 45°	$\pm 1\%$
45 to 60°	Monotonic
Null Repeatability	0.05°
Cross Axis Error	$< 1\%$ up to 45°
Time Constant	0.3 sec
Freq. Response (-3db)	0.5 Hz
RF Susceptibility	$< \pm 2^\circ$

Design concept

The unique design is based on a common capacitor plate sandwiched between sensor housing halves.

The plate has been etched to form two variable capacitors. The assembled sensor is half filled with a dielectric liquid and inert gas. Rotation of the sensor produces a linear change in capacitance resulting in a corresponding output signal.



Ordering information

Model Number	Description
	Ratiometric
02110002-000	Vertical Flange
02110102-000	Horizontal Flange
	Analog
02111002-000	Vertical Flange
02111102-000	Horizontal Flange
	Digital
02112002-000	Vertical Flange
02112102-000	Horizontal Flange
	Serial
02113002-000	Vertical Flange
02113102-000	Horizontal Flange

Dimensions

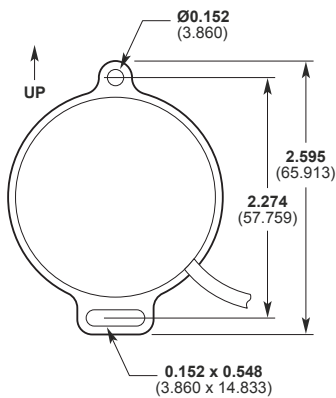

Vertical Flange Mount

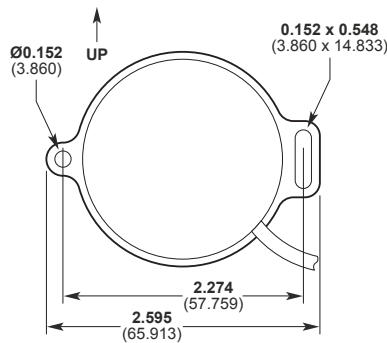

Horizontal Flange Mount

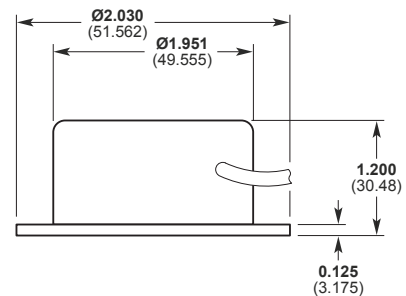

Ratiometric output

The Ratiometric clinometer is a signal conditioned sensor that has been designed to operate like a potentiometer. This is a three wire device: power; power ground; and signal. The signal is referenced to power ground. A regulated power supply is required since the output is supply dependent. The midscale output, zero degrees, is 1/2 the supply voltage while the scale factor is also supply dependent. With its low power consumption, 0.5 mA, this device is ideal for battery supplied applications. The Ratiometric clinometer was designed with EMI and ESD suppression circuitry on every line.

Features

- Low power consumption
- 3 wire operation

Ratiometric Output with 9V DC supply

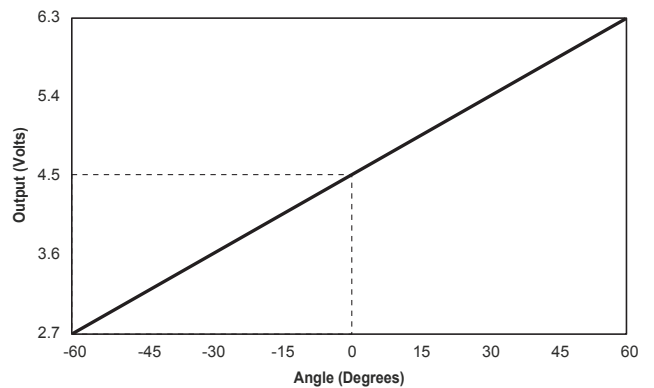

Ratiometric Electrical specifications

Voltage

Voltage Supply

Nominal	+9 VDC
Range (regulated)	+5 to +15 VDC
Current	0.5mA
Scale Factor	
Nominal (@ 9VDC)	30mV/degree \pm 10%
Load Resistance (min.)	10 kOhms
Level Output (0°)	1/2Vcc

Ratiometric I/O block diagram

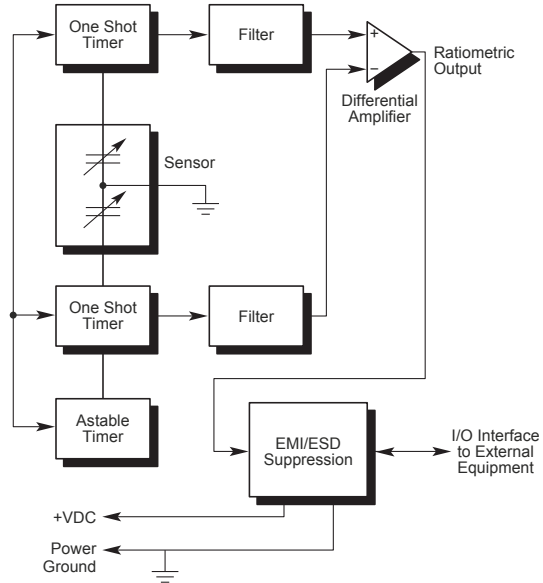

Electrical connections

Wire	Source
Black	Power ground
Red	Reg. +5 to +15 VDC
Yellow	Signal output (reference to power ground)

Analog output

The Analog clinometer is a signal conditioned sensor which has been designed for dc voltage, bipolar operation. The clinometer requires a bipolar supply of ± 8 to ± 15 VDC and delivers an output of ± 3.6 VDC. This device is internally regulated for various applications. The output scale is fixed at a nominal 60mV per degree not dependent on the supply voltage. The Analog clinometer has full EMI and ESD suppression circuitry on every line.

Features

- Internally regulated
- Bipolar input/output

Analog Output

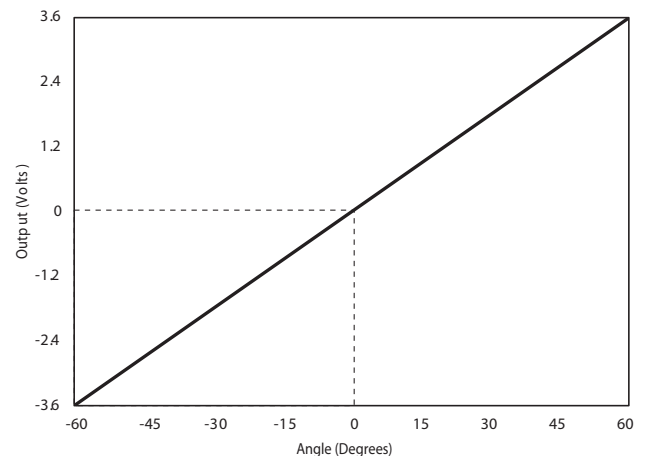

■ Analog electrical specifications

Voltage

Voltage Supply	
Nominal	± 12 VDC
Range (regulated)	± 8 to ± 15 VDC
Current	5mA/supply
Scale Factor	60mV/degree ± 10%
Load Resistance (min.)	10 kOhms
Level Output (0°)	0 VDC

■ Electrical connections

Wire	Source
Black	Power ground
Red	+8 to +15 VDC
Gray	-8 to -15 VDC
Blue	Signal output (reference to power ground)

■ Analog

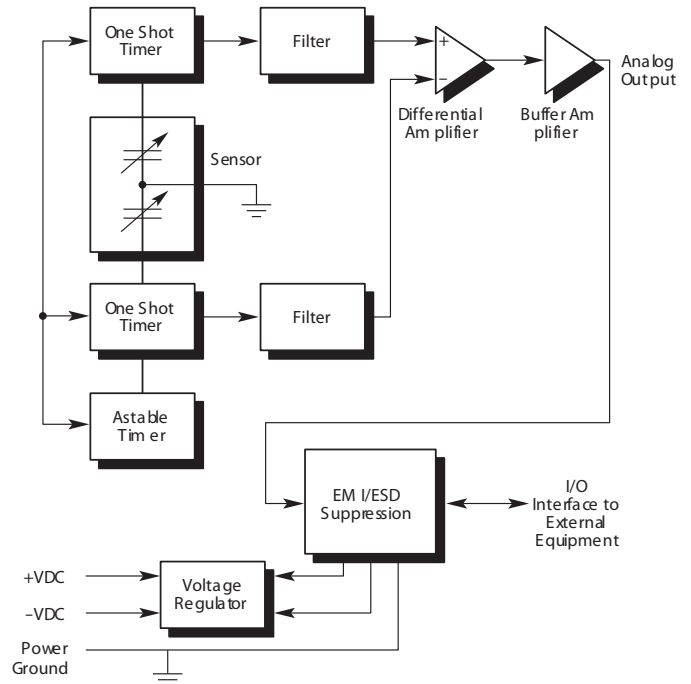

Serial data output

The Serial clinometer is a signal conditioned sensor which resolves the angle of tilt to 16 bits of information plus a polarity bit. This device was designed to transmit data to a microcontroller or to an I/O card of a PC through a three wire interface which will work at both TTL and CMOS logic levels. Complete handshaking is used to eliminate timing and transmission problems. The standard version operates on a +5 VDC regulated power supply while an internally regulated version is available. The Serial clinometer was designed with EMI and ESD suppression circuitry on every line.



Example
 $+31.84^\circ = 1\ 0111\ 1100\ 0110\ 0000$

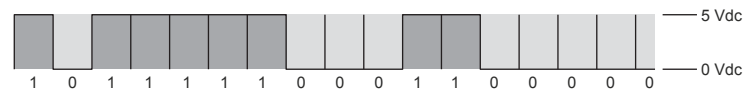

Contact factory for more details.

Features

- Microcontroller compatible
- Ideal for noisy environments

Serial electrical specifications

Voltage

Voltage Supply

Range	+5 VDC, ± 5%
Current	15 mA
Scale Factor	1000 counts/degree ± 10%
Output	CMOS/TTL
Level Output (0°)	0 counts
Binary Range	16 bits + 1 bit polarity (serial)

Serial I/O block diagram

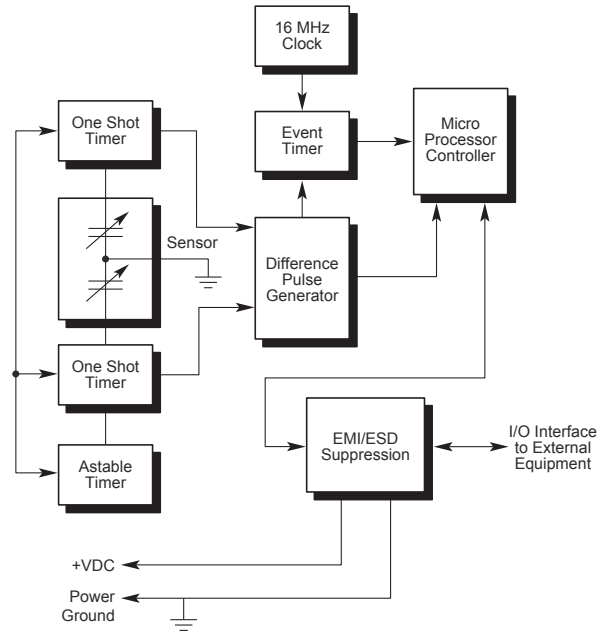

Electrical connections

Wire	Source
Black	Power ground
Red	+5 VDC
Yellow	Data
White	Request/Hold
Gray	Ready/Wait

Digital pulse width output

The Digital Pulse Width clinometer is a signal conditioned sensor which resolves the angle of tilt to pulses, the length of which are directly proportional to the angle. When a trigger pulse is received on trigger 1 or trigger 2 a pulse is sent out the corresponding PW1 or PW2 line. Comparing the length of the two pulses determines the angle of the sensor. Triggering both lines together allows the user to read Delta PW which is the difference of PW1 and PW2. The polarity line will tell the user if the sensor is tilted clockwise or counterclockwise. The Digital Pulse Width clinometer was designed with EMI and ESD suppression circuitry on every line.

Features

- Internally regulated
- Pulse width output

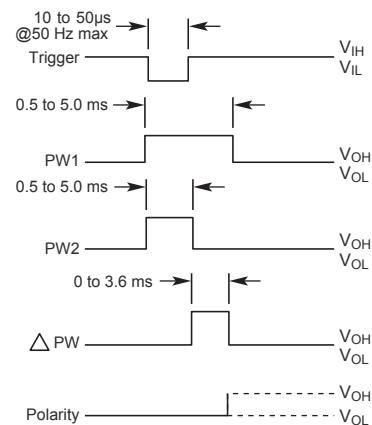

V_{IH} (max) 5.3V	V_{OH} (min) 4.95V
V_{IH} (min) 3.0V	V_{OL} (max) 0.05V
V_{IL} (max) 0.8V	Polarity updated on falling edge of ΔPW
	Polarity high CW, low CCW

Voltage output is TTL compatible. Each output can drive one low power Schottky or multiple CMOS devices.

Data electrical specifications

Voltage

Voltage Supply

Nominal	12 VDC
Range	8 to 15 VDC
Current	5 mA
Scale Factor	60 μ sec/degree \pm 10%
Load Resistance	10K ohms
Level Output (0°)	DPW = 0 sec. PW1 = PW2
Trigger Pulse (CE version)	10 to 50 μ sec @ 50 Hz max.
PW 1 /PW 2	0.5 to 5 msec
Δ PW	0 to 3.6 msec
Polarity	High (CW) Low (CCW)

Electrical connections

Wire	Source
Black	Ground
Red	8 to 15 VDC
Brown	Trigger 1
Blue	Trigger 2
Green	Polarity
Gray	PW1
White	PW
Yellow	Δ PW

Digital I/O block diagram

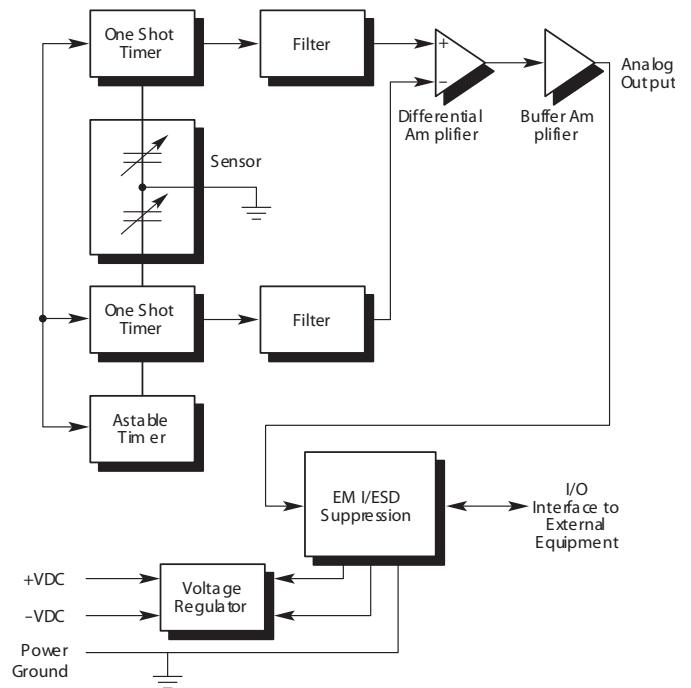

ALTHERIS bv

Scheveningseweg 15
2517 KS DEN HAAG
The Netherlands

+31 (0)70 3924421

+31 (0)70 3644249

Offices in : Benelux | Germany | France | UK | Italy | USA

www.altheris.com

sales@altheris.nl

LEADERS IN SENSORS & HEAVY DUTY JOYSTICKS

ALTHERIS
SENSORS & CONTROLS