



FLF203 Donut Loadcell Standard Ranges 40 and 80tonne (400 and 800kN)

- Hardened stainless steel body
- Sealed to IP65
- Standard 2 year warranty
- Tensile applications are 'fail-safe'
- Very high structural load limit



ALTHEN
MESS- UND SENSORTECHNIK

Geometry: Axial strain cylinder in weather sealed case, with raised end load bearing faces and hole right through. For use in compression or in fail-safe tensile applications.

The FLF203 is ideally suited to engineering force measurements including through centre safety testing of cables, rods and bolts.

It is designed for easy installation, usually between two flat faces bearing on its loading rings, either unattached or with retaining spigots positioned in the centre hole. Alternatively tensile load transfer can be achieved via a tie rod assembly through the centre hole. In this way the loadcell can indirectly measure tensile loads in a "fail-safe" mode.

We are happy to design variants of this loadcell to meet your specific requirements. Versions can be manufactured for operation up to +250°C. Please consult our engineering department.

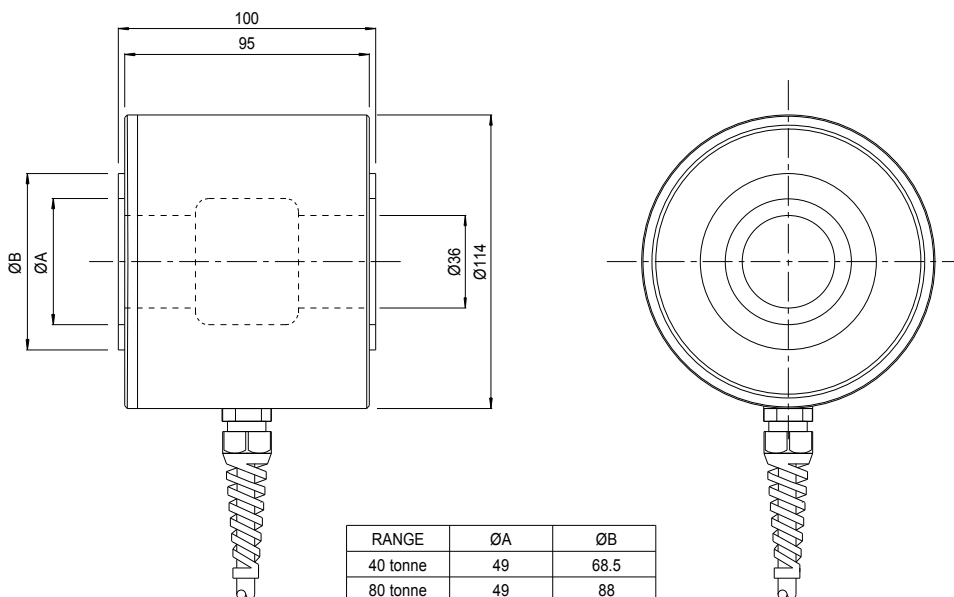

■ Specifications

Parameter	Value	Unit
Non-linearity - Terminal	±0.5	% RL
Hysteresis	±0.5	% RL
Creep - 20 minutes	±0.05	% AL
Repeatability	±0.02	% RL
Rated output - Nominal	1.2	mV/V
Rated output - Rationalised	1.0	mV/V
Rationalisation tolerance	±0.5	% RL
Zero load output	±4	% RL
Temperature effect on rated output per °C	±0.005	% AL
Temperature effect on zero load output per °C	±0.03	% RL
Temperature range - Compensated	-10 to +50	°C
Temperature range - Safe	-10 to +80	°C
Excitation voltage - Recommended	10	V
Excitation voltage - Maximum	20	V
Bridge resistance	700	Ω
Insulation resistance - Minimum at 50Vdc	500	MΩ
Overload - Safe	50	% RL
Overload - Ultimate	400	% RL
Sealing	IP65	
Weight - Nominal (excluding cable)	5 to 5.5	kg

All standard ranges are manufactured in stainless steel.

Structural stiffness – Nominal					
Range (kN)	Stiffness (N/m)	Range (kN)	Stiffness (N/m)	Range (kN)	Stiffness (N/m)
400	1×10^{10}	800	2×10^{10}		

■ Notes

1. AL = Applied load.
2. RL = Rated load.
3. Temperature coefficients apply over the compensated range.
4. The load must be applied directly through the central loading axis.

■ Connections

The loadcell is fitted with 2 metres of PVC insulated 4 core screened cable type 16-2-4C.

Excitation + = Red
Excitation - = Blue

Signal + = Yellow
Signal - = Green

Screen = Orange

The screen is not connected to the loadcell body.

■ Ordering codes

See the loadcell ordering code sheet for more details. Add range in the required units.			
FLF203CFR0K0	Compression, IP65, unrationalised	FLF203CFR0KN	Compression, IP65, rationalised

ALTHERIS bv

Scheveningseweg 15
2517 KS DEN HAAG
The Netherlands

☎ +31 (0)70 3924421

☎ +31 (0)70 3644249

Offices in : Benelux | Germany | France | UK | Italy | USA

🌐 www.altheris.com

✉ sales@altheris.nl

LEADERS IN SENSORS & HEAVY DUTY JOYSTICKS

ALTHERIS
SENSORS & CONTROLS