



FLF232/3

Multi Axis Loadcell

Standard Ranges $\pm 10\text{kg}$ to $\pm 500\text{kg}$ ($\pm 100\text{N}$ to $\pm 5\text{kN}$)

- 2 & 3 axis versions
- Custom force ranges
- Simple installation
- Direct output from each axis without calculation
- Standard 2 year warranty



ALTHEN
MESS- UND SENSORTECHNIK

The FLF232 measures forces in two axes at 90° and the FLF233 measures forces in 3 mutually perpendicular axes. Apart from error evaluations, each output is pure and requires no mathematical manipulation. The loadcell is moment sensitive requiring calibration to be carried out at a specified force centre. The standard centre is specified in the specification. If this is not suitable for your application please consult our engineering department about alternative calibrations.

The FLF232/3 is ideally suited to many industrial and scientific applications, including automotive and medical research.

We are happy to design variants of this loadcell to meet your specific requirements. Versions can be manufactured for higher temperature operation. Please consult our engineering department.

The loadcell can be manufactured with force ranges to suit the application. The Z axis can have a different force range from the X and Y axes. Please consult our engineering department about the viability of the required ranges. The example shown in the picture and drawing is a $\pm 50\text{kg}$ model; there will be small differences in the dimensions for other ranges.

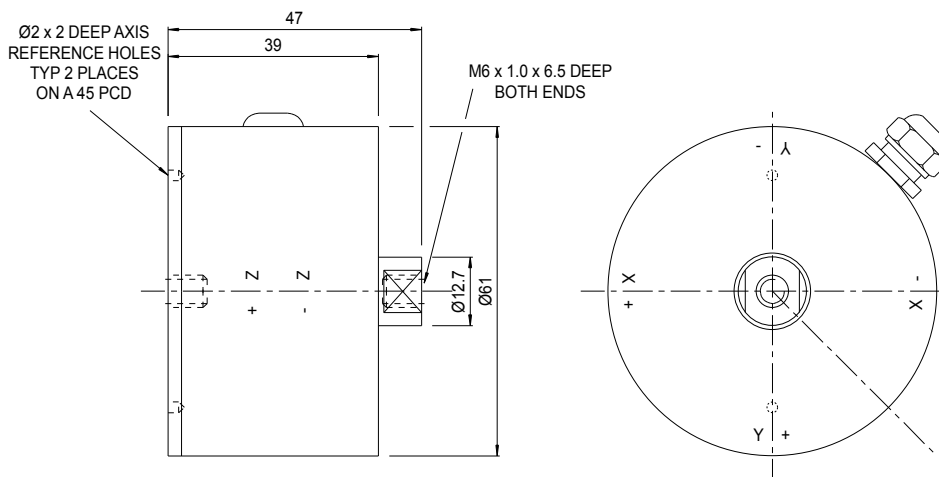

Specifications

Parameter	Value	Unit
Non-linearity - Terminal	±0.5	% RL
Hysteresis	±0.5	% RL
Creep - 20 minutes	±0.1	% AL
Repeatability	±0.02	% RL
Maximum cross talk	3	% RL
Calibration force centre	x=0, y=0, z=-4.5	mm
Rated output - Nominal	1.2	mV/V
Zero load output	±4	% RL
Temperature effect on rated output per °C	±0.005	% AL
Temperature effect on zero load output per °C	±0.01	% RL
Temperature range - Compensated	-10 to +50	°C
Temperature range - Safe	-10 to +80	°C
Excitation voltage - Recommended	10	V
Excitation voltage - Maximum	10	V
Bridge resistance X & Y axis	350	Ω
Z axis	700	Ω
Insulation resistance - Minimum at 50Vdc	500	MΩ
Overload - Safe	50	% RL
Overload - Ultimate	100	% RL
Weight - Nominal (excluding cable)	200	g

Manufactured in aluminium or stainless steel, depending on the load range.

Structural stiffness – Nominal					
Range (N)	Stiffness (N/m)	Range (kN)	Stiffness (N/m)	Range (kN)	Stiffness (N/m)
100 (per axis)	4.3×10^6	5 (per axis)	2.1×10^8		

Notes

- AL = Applied load.
- RL = Rated load.
- Temperature coefficients apply over the compensated range.
- Values apply to all axes unless otherwise specified.

Connections

The FLF232 is fitted with 2 metres of PVC insulated 9 core screened cable type 7-1-9C.
The FLF233 is fitted with 2 metres of PVC insulated 12 core screened cable type 7-1-12C.
The screen is not connected to the loadcell body.

Function	Wire Colour		
	X axis	Y axis	Z axis
Excitation +	Red	Violet	Orange
Excitation -	Blue	Black	Turquoise
Signal +	Yellow	Brown	Pink
Signal -	Green	White	Grey
Screen	Orange (thick)		

Ordering codes

See the loadcell ordering code sheet for more details. Add ranges in the required units.
Most FLF232/3 loadcells are manufactured to special requirements and are given an FLF232-Zxxxx or FLF233-Zxxxx number

ALTHERIS bv

Scheveningseweg 15
2517 KS DEN HAAG
The Netherlands

+31 (0)70 3924421

+31 (0)70 3644249

Offices in : Benelux | Germany | France | UK | Italy | USA

www.altheris.com

sales@altheris.nl

LEADERS IN SENSORS & HEAVY DUTY JOYSTICKS

ALTHERIS
SENSORS & CONTROLS