



FTF315

Low Range Disc Type Static Torque Transducer

Standard Ranges 10 milliNm to 5Nm

- Custom torque ranges
- Symmetrical outputs
- Easy installation
- Standard 2 year warranty

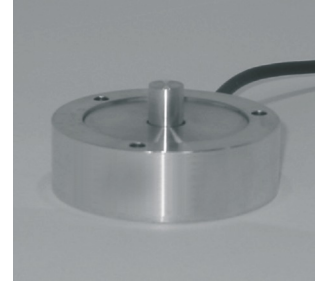

Geometry: Slender disc, with outer ring earth fixing and live inner boss usually shaft driven.

This static torque transducer is used extensively in instrumentation and small electric motor test and calibration applications.

Torque transmission must be arranged to input only torque as extraneous forces, such as tare loads or axial loads will cause measurement errors. Note we are able to calibrate with extraneous load cases replicated.

The highly symmetrical signal outputs are usually between 0.2 and 1mV/V for full range.

We are happy to design variants of this transducer to meet your specific requirements. Please consult our engineering department.

If you require a higher torque range than 5Nm the FTF311 is available with ranges up to 1000Nm.

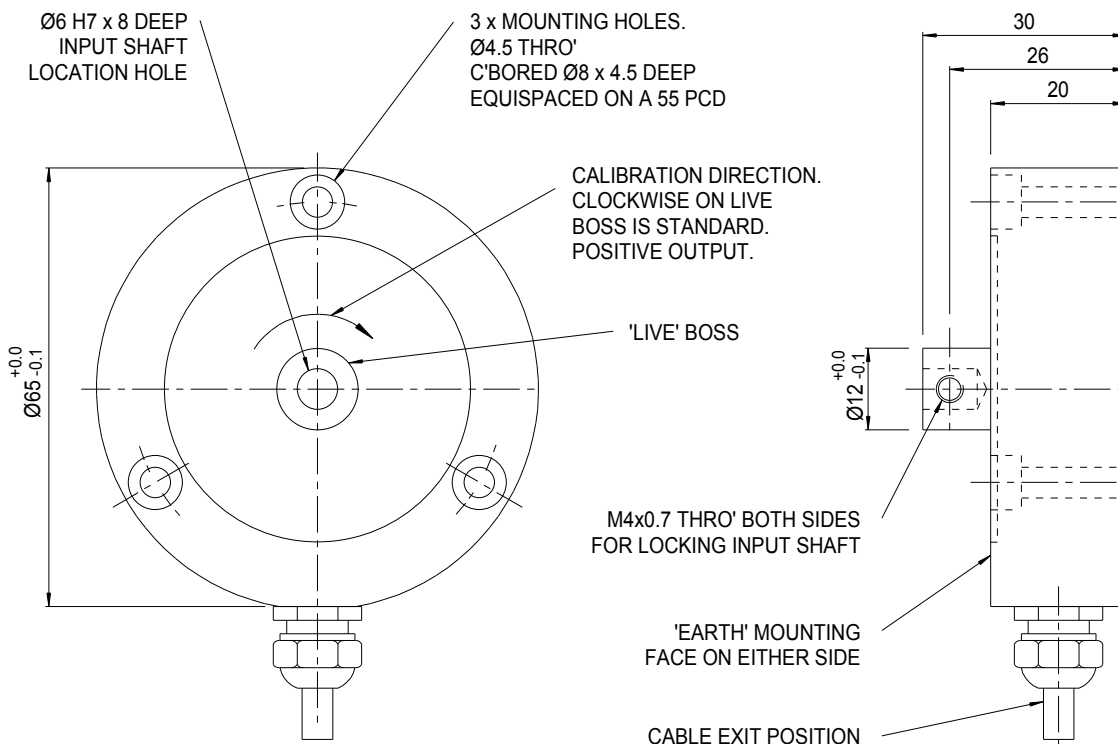

Specifications

Parameter	Value	Unit
Non-linearity - Terminal	±0.05	% RT
Hysteresis	±0.1	% RT
Creep - 20 minutes	±0.3	% AT
Repeatability	±0.05	% RT
Rated output – Nominal (depends on range)	0.2 to 1	mV/V
Zero load output	±4	%
RT Temperature effect on rated output per °C	±0.005	% AT
Temperature effect on zero load output per °C (1mV/V)	±0.01	%
RT Temperature range - Compensated	-10 to +50	°C
Temperature range - Safe	-10 to +80	°C
Excitation voltage - Recommended	10	V
Excitation voltage - Maximum	15	V
Bridge resistance	700	Ω
Insulation resistance - Minimum at 50Vdc	500	MΩ
Overload - Safe	25	%
RT Overload - Ultimate	50	%
RT Weight - Nominal (excluding cable)	110 to 130	g

All standard ranges are manufactured in aluminium.

Notes

- 1. AT = Applied torque.
- 2. RT = Rated torque.
- 3. Temperature coefficients apply over the compensated range.
- 4. Avoid applying axial or side loads to the central boss.

Connections

The transducer is fitted with 2 metres of PVC insulated 4 core screened cable type 7-2-4C.

Excitation + = Red Signal + = Yellow Screen = Orange
 Excitation - = Blue Signal - = Green

The signal connections are for a positive signal for a clockwise torque on the centre boss.
 The screen is not connected to the transducer body.

Ordering codes

See the ordering code sheet for more details. Add range in the required units.
Most FTF315 transducers are manufactured to special requirements and are given an FTF315-Zxxxx number.

ALTHERIS bv

Scheveningseweg 15
 2517 KS DEN HAAG
 The Netherlands

+31 (0)70 3924421 www.altheris.com
 +31 (0)70 3644249 sales@altheris.nl
 Offices in : Benelux | Germany | France | UK | Italy | USA

LEADERS IN SENSORS & HEAVY DUTY JOYSTICKS

