



## FPDMK331 Industrial Pressure Transmitter

- Ceramic sensor
- accuracy according to IEC 60770: 0.5 % FSO

The industrial pressure transmitter FPDMK 331 with ceramic sensor has been especially designed for pasty, polluted or aggressive media and for oxygen applications at low pressure range.

You may choose between various electrical and mechanical connections.

### Preferred areas of use



Plant and Machine Engineering



Environmental Engineering  
(water - sewage - recycling)



Energy Industry



Medical Technology



### Nominal pressure

- from 0 ... 400 mbar
- up to 0 ... 600 bar

### Output signals

- 2-wire: 4 ... 20 mA
- 3-wire: 0 ... 20 mA / 0 ... 10
- others on request

### Special Characteristics

- pressure port G 1/2" flush for pasty and polluted media
- pressure port G 1/2" open port PVDF for aggressive media
- oxygen application

### Optional Versions

- IS-version Ex ia = intrinsically safe for gases and dusts
- SIL 2 according to IEC 61508 / IEC 61511
- customer specific versions

## ■ Technical data

Input pressure range <sup>1</sup>																		
Nominal pressure gauge [bar]	-1.0	0.4	0.6	1	1,6	2,5	4	6	10	16	25	40	60	100	160	250	400	600
Nominal pressure abs. [bar]	-	-	0.6	1	1,6	2,5	4	6	10	16	25	40	60	100	160	250	400	600
Overpressure [bar]	4	1	2	2	4	4	10	10	20	40	40	100	100	200	400	400	600	800
Burst pressure ≥ [bar]	7	2	4	4	5	5	12	12	25	50	50	120	120	250	500	500	650	880
Vacuum resistance	P <sub>N</sub> ≥ 1 bar: unlimited vacuum resistance P <sub>N</sub> < 1 bar: on request																	
<sup>1</sup> PVDF pressure port possible for nominal pressure ranges up to 60 bar																		
Output signal / Supply																		
Standard	2-wire: 4 ... 20 mA / V <sub>S</sub> = 8 ... 32 V <sub>DC</sub>																	
Option IS-protection	2-wire: 4 ... 20 mA / V <sub>S</sub> = 10 ... 28 V <sub>DC</sub>																	
Options 3-wire	3-wire: 0 ... 20 mA / V <sub>S</sub> = 14 ... 30 V <sub>DC</sub> 0 ... 10 V / V <sub>S</sub> = 14 ... 30 V <sub>DC</sub>																	
Performance																		
Accuracy <sup>2</sup>	≤ ± 0.5 % FSO																	
Permissible load	current 2-wire: R <sub>max</sub> = [(V <sub>S</sub> - V <sub>Smin</sub> ) / 0.02] Ω      current 3-wire: R <sub>max</sub> = 500 Ω voltage 3-wire: R <sub>min</sub> = 10 kΩ																	
Influence effects	supply: 0.05 % FSO / 10 V      load: 0.05 % FSO / kΩ																	
Long term stability	≤ ± 0.3 % FSO / year at reference conditions																	
Response time	2-wire: ≤ 10 msec      3-wire: ≤ 3 msec																	
<sup>2</sup> accuracy according to IEC 60770 --limit point adjustment (non-linearity, hysteresis, repeatability)																		
Thermal effects (Offset and Span) / Permissible Temperatures																		
Thermal error	≤ ± 0.2 % FSO / 10 K																	
in compensated range	-25 ... 85 °C																	
Permissible temperatures	medium: -40 ... 125 °C      electronics / environment: -40 ... 85 °C      storage: -40 ... 100 °C																	
Electrical protection																		
Short-circuit protection	permanent																	
Reverse polarity protection	no damage, but also no function																	
Electromagnetic compatibility	emission and immunity according to EN 61326																	
Mechanical stability																		
Vibration	10 g RMS (25 ... 2000 Hz)      according to DIN EN 60068-2-6																	
Shock	500 g / 1 msec      according to DIN EN 60068-2-27																	
Materials																		
Pressure port	standard: stainless steel 1.4404 (316 L) optional for G1/2" open port with nominal pressure range up to 60 bar: PVDF others on request																	
Housing	stainless steel 1.4404 (316 L)																	
Option compact field housing	stainless steel 1.4305 (303) with cable gland brass, nickel plated      others on request																	
Seals (media wetted)	standard: FKM      options: EPDM (for P <sub>N</sub> ≤ 160 bar), NBR      others on request																	
Diaphragm	ceramic Al <sub>2</sub> O <sub>3</sub> 96 %																	
Media wetted parts	pressure port, seals, diaphragm																	
Explosion protection (with option IS-protection)																		
Approval DX19-FPDMK 331	IBExU 10 ATEX 1068 X stainless steel pressure port: zone 0: II 1G Ex ia IIC T4 Ga zone 20: II 1D Ex ta IIIC T 85°C, IP6x <b>in preparation</b> plastic pressure port: zone 1: II 2G Ex ia IIC T4 Ga zone 21: II 2D Ex tD A21 IP6x T 85°C <b>in preparation</b>																	
Safety technical maximum values	U <sub>i</sub> = 28 V <sub>DC</sub> , I <sub>i</sub> = 93 mA, P <sub>i</sub> = 660 mW, C <sub>i</sub> ≈ 0 nF, L <sub>i</sub> ≈ 0 μH																	
Permissible temperatures for environment	in zone 0: -20 ... 60 °C with p <sub>atm</sub> 0.8 bar up to 1.1 bar in zone 1 or higher: -20 ... 70 °C																	
Connecting cables (by factory)	cable capacitance: signal line/shield also signal line/signal line: 160 pF/m cable inductance: signal line/shield also signal line/signal line: 1 μH/m																	
Miscellaneous																		
Option SIL 2	according to IEC 61508 / IEC 61511																	
Option oxygen application	for P <sub>N</sub> ≤ 25 bar: O-ring in special material with oxygen-approval (FKM)																	
Current consumption	signal output current: max. 25 mA      signal output voltage: typ. 5 mA																	
Weight	approx. 140 g																	
Installation position	any																	
Operational life	> 100 x 10 <sup>6</sup> pressure cycles																	
CE-conformity	EMC Directive: 2004/108/EC      Pressure Equipment Directive: 97/23/EC (module A) <sup>3</sup>																	
<sup>3</sup> This directive is only valid for devices with maximum permissible overpressure > 200 bar																		

## ■ Wiring diagrams

### Wiring diagrams

2-wire-system (current)

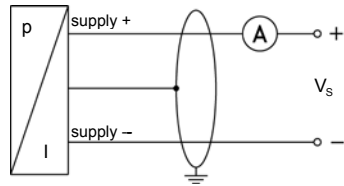

3-wire-system (current / voltage)

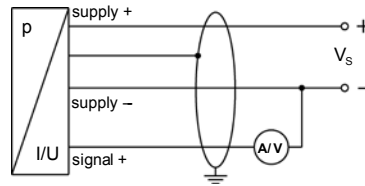

## ■ Pin configuration

Electrical connection	ISO 4400	Binder 723 (5-pin)	M12x1 / metal (4-pin)	field housing	cable colours (DIN 47100)
Supply +	1	3	1	IN +	wh (white)
Supply -	2	4	2	IN -	bn (brown)
Signal + (for 3-wire)	3	1	3	OUT+	gn (green)
Shield	ground pin	5	4	⏏	gn/ye green / yellow

## ■ Electrical connections (dimensions in mm)

### standard

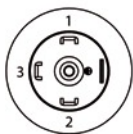
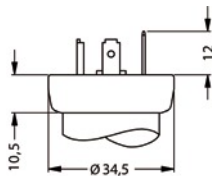

ISO 4400  
PVC cable  
(IP 65)

### option

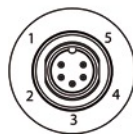
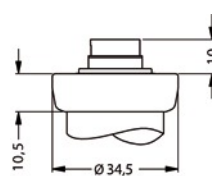

Binder Series 723 5-pin  
(IP 67)

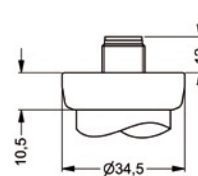

M12x1 4-pin  
(IP 67)

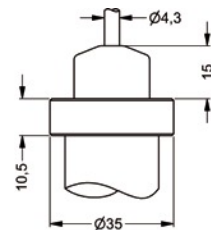

cable outlet with  
(IP 67)<sup>4</sup>

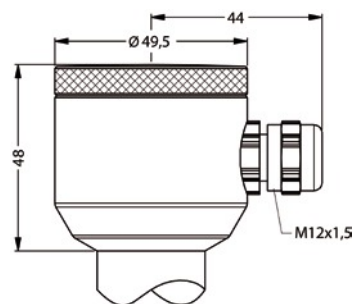

compact field housing  
(IP 67)  
ventilation tube

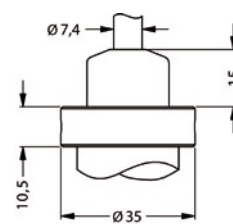

cable outlet,  
cable with  
(IP 68)<sup>5</sup>

⇒ universal field housing stainless steel 1.4404 (316 L) with cable gland M20x1.5 (ordering code 880) and other versions on request

<sup>4</sup> standard: 2 m PVC cable without ventilation tube (permissible temperature: -5 ... 70°C)

<sup>5</sup> different cable types and lengths available, permissible temperature depends on kind of cable

■ Mechanical connection (dimensions in mm)

standard

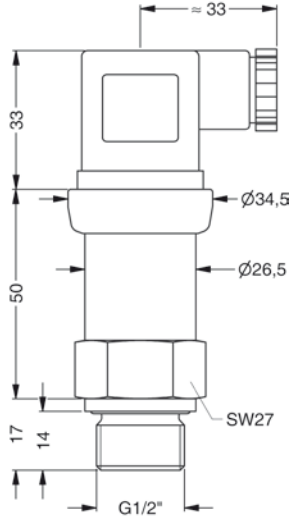

G1/2" DIN 3852  
with ISO 4400

standard for SIL- and SIL-IS-version

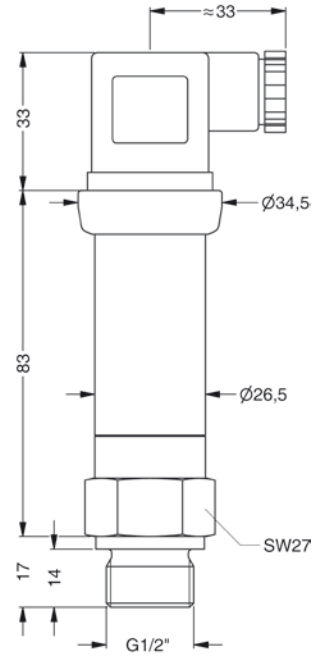

G1/2" DIN 3852  
with ISO 4400

option

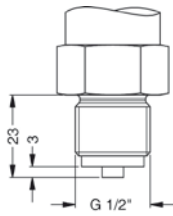

G1/2" EN 837

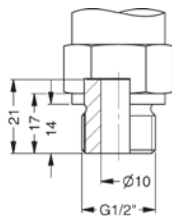

G1/2" open port

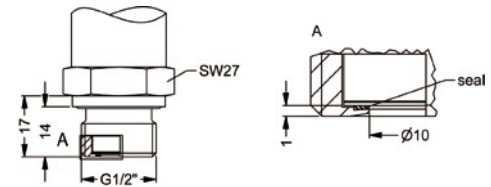

G1/2" semi-flush DIN 3852; M20x1.5<sup>6</sup>

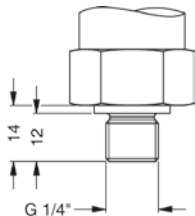

G1/4" DIN 3852

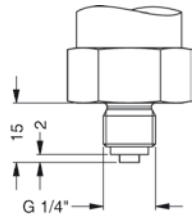

G1/4" EN 837

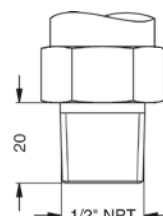

1/2" NPT

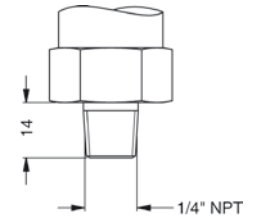

1/4" NPT

⇒ metric threads and other versions on request

<sup>6</sup> possible for nominal pressure ranges  $P_N \leq 25$  bar

