



FPEPRB-1 Pressure Transducer

- Miniature Design (body $\varnothing 11$ mm)
- Any liquid or gas Media compatible with Stainless Steel
- Operating Temperature up to 150°C (300°F)
- Rugged for Severe Environment
- CE Approved



Ultra Miniature Pressure Transducer, 100% Stainless Steel welded construction with amplified output, designed for severe environment where minimum size and weight are required.

Features

- Liquid and Gas Media compatible with SS
- Ranges from 3.5 to 350 bar (50 to 5,000 PSI)
- Operating Temperature up to 150°C (300°F)
- Combined NL&H $\pm 0.25\%$

Applications

- Motorsports
- Downhole Exploration
- Hydraulic Pressures
- Transportation

Standard ranges

Pressure ranges		Pressure Reference		Pressure limit	Pressure limit
(BAR)	(PSI)	sealed (type2)	abs. (type3)	Model : N & V	Model : S & Q
3.5	50	•	•	2 x FS	2 x FS
6	100	•	•	2 x FS	2 x FS
10	150	•	•	2 x FS	2 x FS
20	300	•	•	2 x FS	2 x FS
35	500	•	•	2 x FS	2 x FS
60	1K	•	•	2 x FS	2 x FS
100	1.5K	•	•	2 x FS	2 x FS
200	3K	•	•	1 x FS	1.5 x FS
350	5K	•	•	Not available	1.2 x FS

■ Performance specifications

PARAMETERS	VALUES	NOTES
Supply Voltage	Version U: 8 to 32VDC ; Version R: 5 VDC reg.	
Max Current	< 8 mA	
Output Resistance	200Ω typ.	
Non-Repeatability	± 0.05% FSO typ.	
CNL & H	± 0.25% FSO	
Thermal Zero Shift "TZS"	± 1% /100 °C	
Thermal Sensitivity Shift "TSS"	± 1% /100 °C	
Operating Temperature	- 40°C to 150°C	
Compensated Temperature	0°C to 100°C	See option table for other Temperature
Output "FSO"	0.5 to 4.5V = 4V ± 50mV	
Zero Offset at 23°C	0.5V ± 50mV	
CE conformance according to	EN 61010-1, EN 50081-1, EN 50082-1	

■ Dimensions

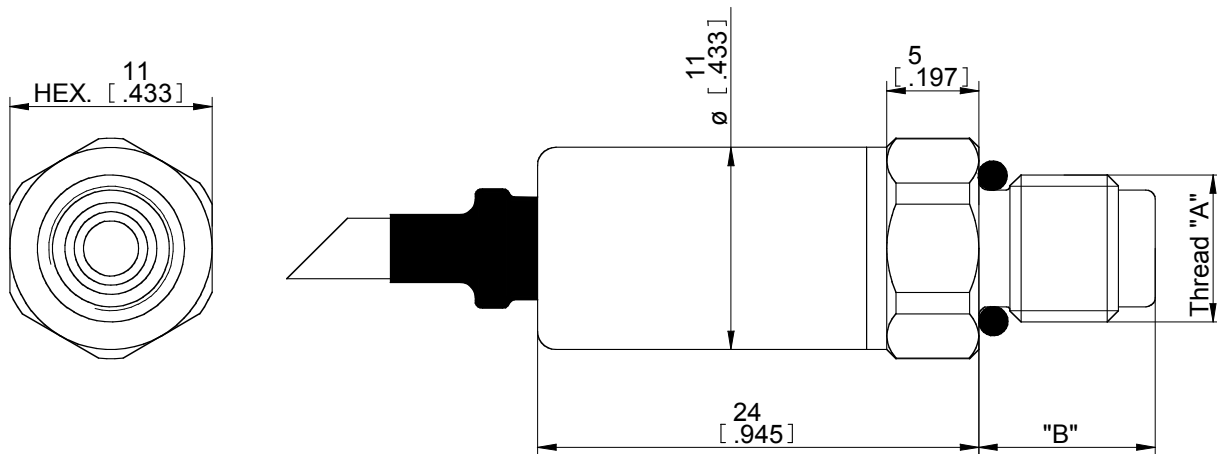

PHYSICAL (SEE BLOCK DIAGRAM)				
MODEL	THREAD "A"	THREAD LENGTH "B"	O-RING SUPPLIED	INSTALLATION TORQUE (MAX.)
N	M5x0.8	8.6 (.34")	Ø3.5x1.5 VITON	1 Nm (9 In-Pounds)
V	10-32 UNF-2A	8.6 (.34")	Ø3.5x1.5 VITON	1 Nm (9 In-Pounds)
S	M8X1	9.6 (.38")	Ø6.35x1.6 VITON	2.5 Nm (22 In-Pounds)
Q	5/16-24 UNF-2A	9.6 (.38")	Ø6.35x1.6 VITON	2.5 Nm (22 In-Pounds)

■ Installation & Connection

RECOMMENDED MOUNTED PORT			
Thread "A"	Dim. "B"	Dim. "C"	Dim. "D"
M5x0.8	5.6 mm	1.5 mm	0.2 mm
10-32 UNF	0.22"	0.060"	0.01"
M8x1	8.8 mm	1.9 mm	0.4 mm
5/16-24 UNF-2A	0.35"	0.075"	0.015"

Tolerances on dimensions = ± 0.05 mm (0.002")

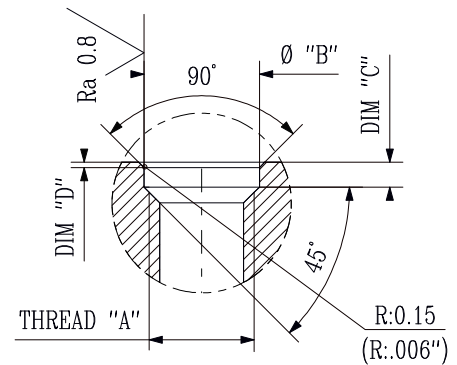

WIRING: 3 leads AWG24 under shrink tube

Standard cable length = 1 m.
Use option L00M for custom cable length:
replace "00" with total length in meter

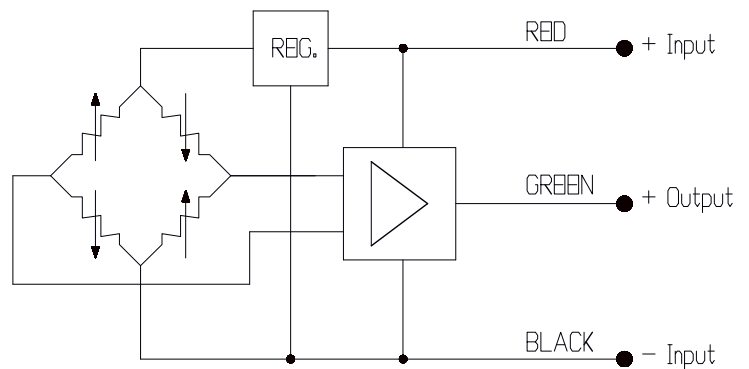

■ Options and Accessories

OPTIONS	CODES	DESCRIPTIONS
Compensated Temperature Ranges	Z1	-20°C to 40°C
	Z35	+20°C to 120°C
Special Cable Length	L00M	Replace "00" with total length in meters
Acceptance Test Report	ATR	ATR for a complete Acceptance Test Report provided with transducer

■ Ordering information

Model	-	Pressure Port	Supply Voltage	Output Signal	Pres. Ref.	-	Range/Unit		-	Options
FPEPRB-1	-	N = M5x0.8 V = 10-32 UNF S = M8x1 Q = 5/16-24 UNF	U = 8 to 32 VDC R = 5 VDC reg.	3 = 0.5 to 4.5 V	2 = Sealed 3 = Absolute	-	3.5B 6B 10B 20B 35B 60B 100B 200B 350B	50P 100P 150P 300P 500P 1KP 1.5KP 3KP 5KP	-	/Z1 /Z35 /L00M /ATR

Example: FPEPRB-1-VU32-500P-/Z1/L5M

ALTHERIS bv

Scheveningseweg 15
2517 KS DEN HAAG
The Netherlands

☎ +31 (0)70 3924421

☎ +31 (0)70 3644249

Offices in : Benelux | Germany | France | UK | Italy | USA

🌐 www.altheris.com

✉ sales@altheris.nl

LEADERS IN SENSORS & HEAVY DUTY JOYSTICKS

ALTHERIS
SENSORS & CONTROLS