

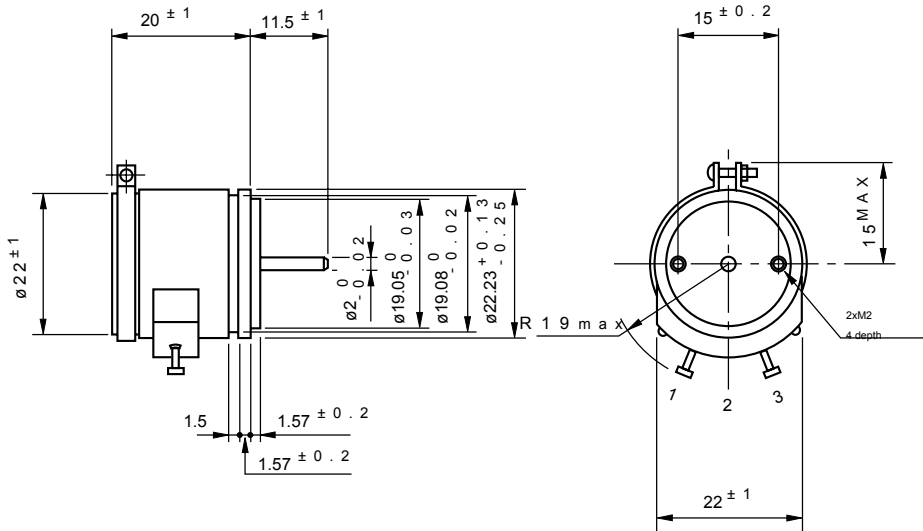

LNB22

Wirewound (Servomount)

Standard dimensions



Model LNB22

General Specifications

Standard Resistance

Range: 100Ω to 20kΩ

≥2kΩ

within 0.1mN·m (1.0gf·cm)
(within electrical travel)

Total Resistance

Tolerance: Standard class ±3% (H)
Precision class ±1% (F)

Max. Working Voltage:

80V

Independent Linearity

Tolerance: Standard class ±0.5%
Precision class ±0.25%

Resist. Temperature Coefficient of Wire:

±20p.p.m./°C

Power Rating:

0.3W

Operating Temperature Range:

-30°C ~ +85°C

Noise:

within 100Ω R.E.N.

Life Expectancy, Shaft Revolutions:

100,000

Electrical Travel:

355° ± 5°

Mass:

Approx 20g

Mechanical Travel:

360° (Endless)

Insulation Resistance:

over 1,000MΩ at 1,000V.D.C.

Dielectric Strength:

1 minute at 1,000V.A.C.

Starting Torque:

<2kΩ
within 0.15mN·m (1.5gf·cm)
(within electrical travel)

Standard Resistance Values | No. of Wire Turns | Resistance Wire Used

Resist. Value (Ω)	100	200	500	1k	2k	5k	10k	✳20k
No. of wire turns	3 7 0	4 7 0	4 5 0	5 7 0	7 4 0	1, 0 0 0	1, 2 7 0	1, 6 7 0
Resist. wire used	Cu-Ni System			Ni-Cr system				

Special Specifications Available

Extra taps (Available up to 1 tap), 2 ganged, Shaft with front and rear extension (Rear shaft with 22mm dia. And 10mm length), Special electrical travel, Special machining on the shaft.

■ **Low-torque potentiometer (precision 1-turn, Low-torque, Wirewound Element)**

Altheris Low-torque Potentiometers with a wirewound resistive element are very small in size and light in weight, it offers a very low starting torque of below 0.1mN · m (1gf · cm) in Model LNB22. Electrical detection of

inclination, vibration, etc. is easily possible by installing these potentiometers on float, bellows, etc. These models are only available with wirewound resistive element as standard version.

THE NOMENCLATURE OF LOW TORQUE POT.

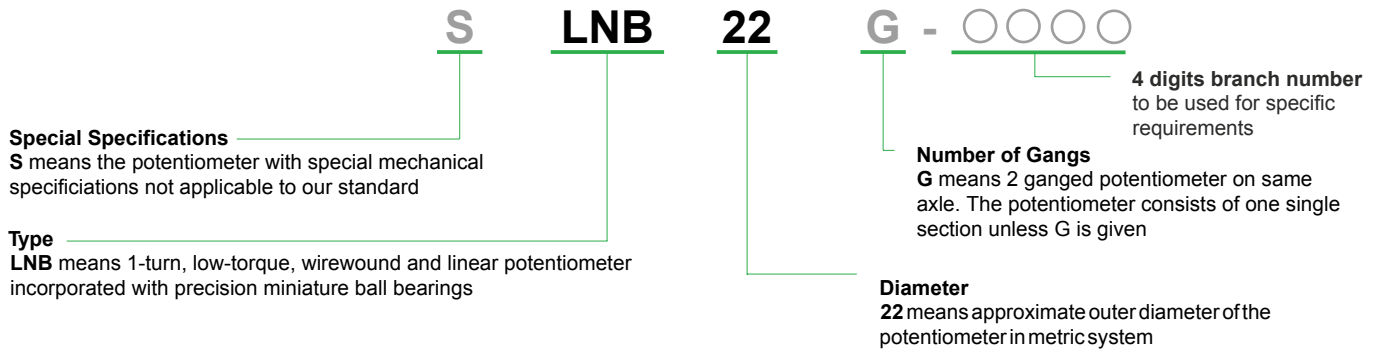

■ **Specimen for reference**

Model SFCP18A-2172F



(1-turn Pot. With special housing case and completely sealed -IP65-)

Model SLNB30-2546B



(1-turn Pot. With low-torque and special housing case)

ALTHERIS bv

Scheveningseweg 15
2517 KS DEN HAAG
The Netherlands

+31 (0)70 3924421

+31 (0)70 3644249

Offices in : Benelux | Germany | France | UK | Italy | USA

www.altheris.com

sales@altheris.nl

LEADERS IN SENSORS & HEAVY DUTY JOYSTICKS

