

## Model 793T-3 General purpose accelerometer with internal temperature sensor

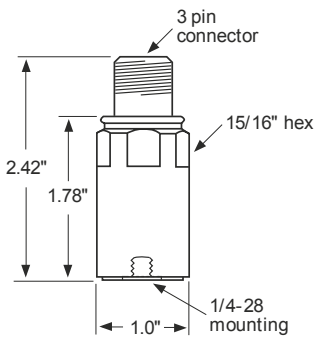

### Features

- Senses both acceleration and temperature
- Rugged design
- Hermetic seal
- Ground isolated
- ESD protection
- Reverse wiring



### Dynamic

Sensitivity, $\pm 5\%$ , 25°C.....	100 mV/g
Acceleration range .....	80 g peak
Amplitude nonlinearity .....	1%
Frequency response:	
$\pm 5\%$ .....	1.5 - 5,000 Hz
$\pm 10\%$ .....	1.0 - 7,000 Hz
$\pm 3$ dB .....	0.5- 15,000 Hz
Resonance frequency .....	24 kHz
Transverse sensitivity, max.....	5% of axial
Temperature response:	
- 50°C .....	- 10%
+120°C .....	+5%
Temperature output sensitivity, $\pm 5\%$ .....	10 mV/°K
Temperature measurement range.....	223 to 390°K (- 50 to 120°C)

### Electrical

#### Temperature sensor

Power requirement:	voltage source .....	18 - 30 VDC
	current regulating diode .....	2 - 4 mA
Grounding .....		case isolated, internally shielded

#### Accelerometer

Power requirement:	voltage source .....	18 - 30 VDC
	current regulating diode .....	2 - 10 mA

#### Electrical noise, equiv. g:

Broadband	2.5 Hz to 25 kHz.....	600 $\mu$ g
Spectral	10 Hz.....	8 $\mu$ g/ $\sqrt$ Hz
	100 Hz.....	5 $\mu$ g/ $\sqrt$ Hz
	1000 Hz.....	5 $\mu$ g/ $\sqrt$ Hz

Output impedance, max.....	100 $\Omega$
Bias output voltage.....	12 VDC
Grounding .....	case isolated, internally shielded

### Environmental

Temperature range.....	- 50 to 120°C
Vibration limit .....	500 g peak
Shock limit .....	5,000 g peak
Electromagnetic sensitivity, equiv. g.....	10 $\mu$ g/gauss
Sealing .....	hermetic
Base strain sensitivity .....	0.0005 g/ $\mu$ strain

### Physical

Sensing element design .....	PZT ceramic / compression
Weight .....	115 grams
Case material .....	316L stainless steel
Mounting.....	1/4-28 tapped hole
Output connector .....	3 pin, MIL-C-5015 style
Mating Connector .....	R6G type
Recommended cabling .....	J9T3A

Connector pin	Function
Shell	ground
A	accelerometer- power & signal
B	accelerometer- temperature / sensor common
C	temperature sensor- power & signal

Accessories supplied: SF6 mounting stud (International customers specify mounting requirements); calibration data (level 3)